

PUNTE ST QPDRILL 3xD

PUNTE ST Q ST Q DRILL

Punte di foratura a fissaggio meccanico con inserto quadro. Altissime prestazioni su tutti i materiali.

Indexable insert drill with square inserts. High performance for all materials.

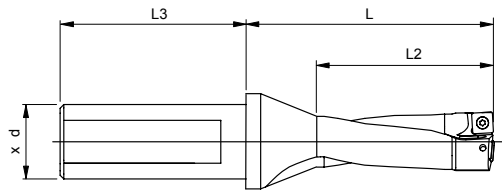

*Punte 3 X D/*Drill 3xD

| gruppo sconto **FOTO** |

DIAMETRI DIAMETERS	3xD 3xD	d x L3 d x L3	TAGLIA INSERTO INSERT SIZE	COD. VITE CODE SCREW	Ø VITE Ø SCREW	Nm Nm.	L L	L 2 L 2	FORI REFR. COOL. HOLES	€
Ø 14	ST Q P 14.00-3D20SC05	20 X 50	SCLX050204...	N00 56041	M2X4.3-6IP	0,5	66	42,0	SI/YES	331,00
Ø 15	ST Q P 15.00-3D20SC05	20 X 50	SCLX050204...	N00 56041	M2X4.3-6IP	0,5	69	45,0	SI/YES	331,00
Ø 15,5	ST Q P 15.50-3D20SC05	20 X 50	SCLX050204...	N00 56041	M2X4.3-6IP	0,5	72	48,0	SI/YES	331,00
Ø 16	ST Q P 16.00-3D20SC05	20 X 50	SCLX050204...	N00 56041	M2X4.3-6IP	0,5	72	48,0	SI/YES	331,00
Ø 16,5	ST Q P 16.50-3D20SC05	20 X 50	SCLX050204...	N00 56041	M2X4.3-6IP	0,5	72	48,0	SI/YES	315,00
Ø 17	ST Q P 17.00-3D20SC06	20 X 50	SCLX060206...	N00 57553	M2.2X5.5-6IP	0,5	75	51,0	SI/YES	331,00
Ø 17,5	ST Q P 17.50-3D25SC06	25 X 56	SCLX060206...	N00 57553	M2.2X5.5-6IP	0,5	78	54,0	SI/YES	336,00
Ø 18,0	ST Q P 18.00-3D25SC07	25 X 56	SCLX060206...	N00 57553	M2.2X5.5-6IP	0,5	78	54,0	SI/YES	336,00
Ø 18,5	ST Q P 18.50-3D25SC06	25 X 56	SCLX060206...	N00 57553	M2.2X5.5-6IP	0,5	81	57,0	SI/YES	336,00
Ø 19,0	ST Q P 19.00-3D25SC06	25 X 56	SCLX060206...	N00 57553	M2.2X5.5-6IP	0,5	81	57,0	SI/YES	336,00
Ø 19,5	ST Q P 19.50-3D25SC06	25 X 56	SCLX060206...	N00 57553	M2.2X5.5-6IP	0,5	84	60,0	SI/YES	336,00
Ø 20,0	ST Q P 20.00-3D25SC07	25 X 56	SCLX070308...	N00 57571	M2.5X6.3-8IP	1,2	84	60,0	SI/YES	336,00
Ø 21,0	ST Q P 21.00-3D25SC07	25 X 56	SCLX070308...	N00 57571	M2.5X6.3-8IP	1,2	87	63,0	SI/YES	347,00
Ø 22,0	ST Q P 22.00-3D25SC07	25 X 56	SCLX070308...	N00 57571	M2.5X6.3-8IP	1,2	90	66,0	SI/YES	347,00
Ø 22,5	ST Q P 22.50-3D25SC07	25 X 56	SCLX070308...	N00 57571	M2.5X6.3-8IP	1,2	93	66,0	SI/YES	347,00
Ø 23,0	ST Q P 23.00-3D25SC07	25 X 56	SCLX070308...	N00 57571	M2.5X6.3-8IP	1,2	93	69,0	SI/YES	347,00
Ø 24,0	ST Q P 24.00-3D32SC08	32 X 60	SCLX080408...	N00 57241	M3X7-8IP	1,2	96	72,0	SI/YES	347,00
Ø 24,5	ST Q P 24.50-3D32SC08	32 X 60	SCLX080408...	N00 57241	M3X7-8IP	1,2	96	72,0	SI/YES	347,00
Ø 25,0	ST Q P 25.00-3D32SC08	32 X 60	SCLX080408...	N00 57241	M3X7-8IP	1,2	99	75,0	SI/YES	347,00
Ø 26,0	ST Q P 26.00-3D32SC08	32 X 60	SCLX080408...	N00 57241	M3X7-8IP	1,2	102	78,0	SI/YES	390,00
Ø 26,5	ST Q P 26.50-3D32SC08	32 X 60	SCLX080408...	N00 57241	M3X7-8IP	1,2	105	81,0	SI/YES	390,00
Ø 27,0	ST Q P 27.00-3D32SC08	32 X 60	SCLX080408...	N00 57241	M3X7-8IP	1,2	105	81,0	SI/YES	390,00
Ø 28,0	ST Q P 28.00-3D32SC08	32 X 60	SCLX080408...	N00 57241	M3X7-8IP	1,2	108	84,0	SI/YES	390,00
Ø 29,0	ST Q P 29.00-3D32SC10	32 X 60	SCLX100408...	N00 57261	M3.5X7.5-15IP	3	111	87,0	SI/YES	390,00
Ø 30	ST Q P 30.00-3D32SC10	32 X 60	SCLX100408...	N00 57261	M3.5X7.5-15IP	3	119	90,0	SI/YES	390,00
Ø 31	ST Q P 31.00-3D32SC10	32 X 60	SCLX100408...	N00 57261	M3.5X7.5-15IP	3	122	93,0	SI/YES	390,00
Ø 32	ST Q P 32.00-3D32SC10	32 X 60	SCLX100408...	N00 57261	M3.5X7.5-15IP	3	125	96,0	SI/YES	499,00
Ø 33	ST Q P 33.00-3D32SC10	32 X 60	SCLX100408...	N00 57261	M3.5X7.5-15IP	3	128	99,0	SI/YES	499,00
Ø 34	ST Q P 34.00-3D32SC10	32 X 60	SCLX100408...	N00 57261	M3.5X7.5-15IP	3	131	102,0	SI/YES	499,00
Ø 35	ST Q P 35.00-3D32SC10	32 X 60	SCLX100408...	N00 57261	M3.5X7.5-15IP	3	134	105,0	SI/YES	499,00
Ø 36	ST Q P 36.00-3D32SC12	32 X 60	SCLX120508...	N00 57301	M4.5X10-20IP	5	137	108,0	SI/YES	499,00
Ø 37	ST Q P 37.00-3D32SC12	32 X 60	SCLX120508...	N00 57301	M4.5X10-20IP	5	150	111,0	SI/YES	499,00
Ø 38	ST Q P 38.00-3D32SC12	32 X 60	SCLX120508...	N00 57301	M4.5X10-20IP	5	153	114,0	SI/YES	499,00
Ø 39	ST Q P 39.00-3D32SC12	32 X 60	SCLX120508...	N00 57301	M4.5X10-20IP	5	156	117,0	SI/YES	499,00
Ø 40	ST Q P 40.00-3D32SC12	32 X 60	SCLX120508...	N00 57301	M4.5X10-20IP	5	159	120,0	SI/YES	499,00
Ø 41	ST Q P 41.00-3D32SC12	32 X 60	SCLX120508...	N00 57301	M4.5X10-20IP	5	162	123,0	SI/YES	499,00
Ø 42	ST Q P 42.00-3D32SC12	32 X 60	SCLX120508...	N00 57301	M4.5X10-20IP	5	165	126,0	SI/YES	499,00
Ø 43	ST Q P 43.00-3D32SC12	32 X 60	SCLX120508...	N00 57301	M4.5X10-20IP	5	168	129,0	SI/YES	499,00
Ø 44	ST Q P 44.00-3D32SC12	32 X 60	SCLX120508...	N00 57301	M4.5X10-20IP	5	171	132,0	SI/YES	499,00

INSERTI PUNTE ST Q

ST Q DRILL INSERTS

Inserti per punte ST Q/ST Q Drill Inserts | gruppo sconto FO20 |

	CODICE CODE	€
D. 14 - 16,5	SCLX050204 PMK25P	13,20
	SCLX050204 PM40P	13,20
	SCLX050204 MS30P	13,20
D. 17 - 19,5	SCLX060206 PMK25P	13,40
	SCLX060206 PM40P	13,40
	SCLX060206 MS30P	13,40
D. 20 - 23	SCLX070308 PMK25P	13,80
	SCLX070308 PM40P	13,80
	SCLX070308 MS30P	13,80
D. 23,5 - 28	SCLX080408 PMK25P	14,10
	SCLX080408 PM40P	14,10
	SCLX080408 MS30P	14,10
D. 29 - 35	SCLX100408 PMK25P	15,10
	SCLX100408 PM40P	15,10
	SCLX100408 MS30P	15,10
D. 36 - 44	SCLX120508 PMK25P	15,80
	SCLX120508 PM40P	15,80
	SCLX120508 MS30P	15,80

INFORMAZIONI TECNICHE/TECHNICAL INFORMATION

GRADI/GRADES

PMK 25P	Universale prima scelta per acciai inox e ghise per elevate velocità di taglio. Riv. PVD <i>Universal first choice for SS and cast iron for high cutting speed. PVD coating.</i>
MS 30P	Micrograno per inox superleghe e acciai con ottima resistenza all'usura. Riv. PVD <i>Micrograin for SS and super alloys and steel with high wear resistance. PVD coating.</i>
PM 40P	Tenace per acciai, inox, superleghe e acciai da stampi con medie e basse velocità di taglio. Riv. PVD. <i>Tough grade for SS super alloys, steel and dies-steel for medium-low cutting speed. PVD coating.</i>

PARAMETRI DI TAGLIO/CUTTING PARAMETERS

Velocità di taglio in metri/minuto / Cutting speed in metres/minute

MATERIALE MATERIAL	PMK 25P	MS 30P	PM 40P
Acciaio dolce/Mild steel	200- 260 -320	180- 220 -280	170- 200 -250
Acciaio basso medio legato/Low medium alloy steel	180- 200 -230	160- 180 -210	140- 170 -190
Acciaio legato stampi-utensili/Alloy steel dies-tools	160- 180 -210	130- 150 -180	110- 130 -150
Inox/SS	130- 150 -180	120- 140 -170	100- 120 -150
Duplex, leghe titanio, inconel 625/Duplex steel, titanium alloys, Inconel 625	65- 80 -85	60- 80 -100	50- 70 -90
Ghisa/Cast iron	130- 180 -220	-	-

Avanzamenti in mm./giro / Feed rate in mm/360°

MATERIALE MATERIAL	DIAMETRI PUNTE/DIAMETERS BITS					
	14-16	16,5 - 19,5	20 - 23	23,5 - 28	29 - 35	36 - 44
Acciaio dolce/Mild steel	0,04- 0,05 -0,06	0,05- 0,07 -0,09	0,06- 0,08 -0,12	0,07- 0,09 -0,12	0,08- 0,11 -0,13	0,09- 0,12 -0,16
Acciaio basso medio legato Low medium alloy steel	0,05- 0,06 -0,07	0,06- 0,09 -0,12	0,08- 0,11 -0,16	0,09- 0,12 -0,16	0,10- 0,14 -0,15	0,12- 0,15 -0,19
Acciaio legato stampi-utensili Alloy steel dies-tools	0,04- 0,05 -0,07	0,05- 0,08 -0,11	0,07- 0,10 -0,13	0,09- 0,11 -0,14	0,09- 0,12 -0,15	0,11- 0,14 -0,17
Inox/SS	0,04- 0,05 -0,06	0,04- 0,06 -0,07	0,05- 0,07 -0,09	0,07- 0,09 -0,11	0,08- 0,11 -0,13	0,08- 0,12 -0,16
Duplex, leghe titanio, inconel 625 Duplex steel, titanium alloys, Inconel 625	0,04- 0,05 -0,06	0,04- 0,05 -0,06	0,05- 0,08 -0,11	0,07- 0,08 -0,11	0,07- 0,09 -0,11	0,07- 0,10 -0,13
Ghisa/Cast iron	0,06- 0,08 -0,10	0,06- 0,09 -0,12	0,08- 0,11 -0,14	0,10- 0,13 -0,16	0,12- 0,15 -0,18	0,15- 0,18 -0,21

PUNTE ST HP

ST HP DRILL

Punte per foratura regolabili con pilota di guida e cartucce. Pattini guida inclusi nella fornitura.

Adjustable drills with guide pilot and cartridges. Guide pads included in the supply.

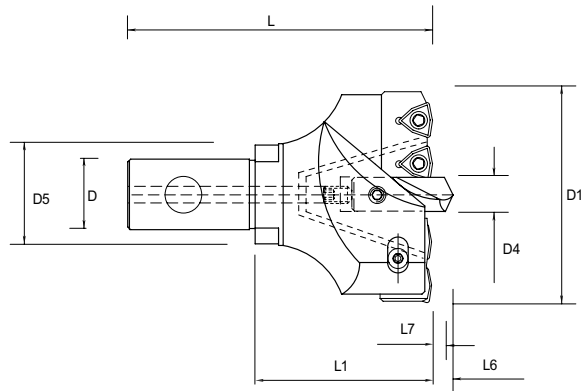

Teste di foratura regolabili/Adjustable drilling heads

| gruppo sconto **FO40** |

DIAMETRI	CODICE	CODICI	D1	d	D4	L1	L	D5	D	€
DIAMETERS	PUNTA CORPO DRILL CODE	CONNESSIONI CONNECTION CODE	Max Max	Min Min	PILOTA PILOT DRILL	UTILE WORKING	TOTALE TOTAL L	APPOGGIO SUPPORT	ACCOUPLAMENTO COUPLING	
Ø 45-50	ST H P 50-5	S08 D03 W18-I50 E51	50	45	8	50	85	28	13	525,00
Ø 50-55	ST H P 55-5	S08 D03 W18-I52 E53	55	50	8	50	85	28	13	525,00
Ø 55-58	ST H P 58-3	S08 D05 W24-I38 E39	58	55	8	60	100	32	16	549,00
Ø 58-63	ST H P 63-5	S10 D05 W24-I23 E24	63	58	10	60	100	32	16	549,00
Ø 63-68	ST H P 68-5-16	S10 D05 W24-I25 E24	68	63	10	60	100	32	16	549,00
Ø 63-68	ST H P 68-5-22	S10 D05 W24-I25 E24	68	63	10	70	115	40	22	549,00
Ø 68-73	ST H P 73-5	S10 D05 W24-I26 E27	73	68	10	70	115	40	22	549,00
Ø 73-78	ST H P 78-5	S15 D05 W24-I26 E27	78	73	15	70	115	40	22	549,00
Ø 78-84	ST H P 84-6-22	S15 D06 W34-I28 E29	84	78	15	70	115	40	22	570,00
Ø 78-84	ST H P 84-6-27	S15 D06 W34-I28 E29	84	78	15	70	120	48	27	570,00
Ø 84-90	ST H P 90-6	S15 D06 W34-I28 E29	90	84	15	70	120	48	27	570,00
Ø 90-96	ST H P 96-6	S15 D06 W34-I30 E31	96	90	15	70	120	48	27	570,00
Ø 96-102	ST H P 102-6-27	S20 D06 W34-I30 E31	102	96	20	70	120	48	27	618,00
Ø 96-102	ST H P 102-6-32	S20 D06 W34-I30 E31	102	96	20	80	130	58	32	618,00
Ø 102-108	ST H P 108-6	S20 D05 W24-I81 E82	108	102	20	80	130	58	32	618,00
Ø 108-115	ST H P 115-7	S20 D06 W34-I83 E84	115	108	20	80	130	58	32	799,00
Ø 115-122	ST H P 122-7	S20 D06 W34-I85 E86	122	115	20	90	145	70	40	799,00
Ø 122-130	ST H P 130-8	S25 D06 W34-I79 E80	130	122	25	90	145	70	40	799,00
Ø 130-140	ST H P 140-10	S25 D06 W34-I87 E88	140	130	25	90	145	70	40	799,00
Ø 140-150	ST H P 150-10	S25 D07 W42-I77 E78	150	140	25	100	160	80	50	1.059,00
Ø 150-158	ST H P 158-8	S25 D07 W42-I75 E76	158	150	25	100	160	80	50	1.059,00
Ø 158-162	ST H P 162-4	S25 D07 W42-I73 E74	162	158	25	100	160	80	50	1.059,00
Ø 180	ST H P 180	S30 D06 W34-I30 E31	180	-	30	120	180	90	50	2.200,00
Ø 190	ST H P 190	S30 D06 W34-I30 E31	190	-	30	120	180	90	50	2.250,00
Ø 200	ST H P 200	S30 D06 W24-I81 E82	200	-	30	130	190	90	50	2.300,00

PUNTE ST HP

ST HP DRILL



CARTUCCE PER INSERTI W29

Cartridges for W29 inserts

Cartucce per punte ST H con inserti KOMET TRIGONI tipo W29 taglia 18-24-34-42
 Cartridges for ST H Drill with KOMET TRIGONI inserts, type W29, sizes 18-24-34-42

| gruppo sconto **F040** |

DIAMETRI Max DIAMETRES MAX	CODICE CARTUCCE INTERNE INTERNAL CARTRIDGES CODE			€	CODICE CARTUCCE ESTERNE EXTERNAL CARTRIDGES CODE			€	N° CARTUCCE		N° INSERTI PER CARTUCCIA No. INSERTS FOR CARTRIDGE	TIPO E TAGLIA INSERTI INSERTS TYPE AND SIZE	VITE FISSAGGIO INSERTO TIPO W29 INSERT FIXING SCREW TYPE W29
	Int.	Est.	Int.		Est.	Int.	Est.						
Ø 50	ST H C 50	I50 W18	102,00	ST H C 50	E51 W18	102,00	1	1	2	W29 18	N0057553		
Ø 55	ST H C 55	I52 W18	102,00	ST H C 55	E53 W18	102,00	1	1	2	W29 18	N0057553		
Ø 58	ST H C 58	I38 W24	102,00	ST H C 58	E39 W24	102,00	1	1	2	W29 24	N0057511		
Ø 63	ST H C 63	I23 W24	102,00	ST H C 6368	E24 W24	102,00	1	1	2	W29 24	N0057511		
Ø 68	ST H C 68	I25 W24	102,00	ST H C 6368	E24 W24	102,00	1	1	2	W29 24	N0057511		
Ø 73	ST H C 7378	I26 W24	102,00	ST H C 7378	E27 W24	102,00	1	1	2	W29 24	N0057511		
Ø 78	ST H C 7378	I26 W24	102,00	ST H C 7378	E27 W24	102,00	1	1	2	W29 24	N0057511		
Ø 84	ST H C 8490	I28 W34	127,00	ST H C 8490	E29 W34	127,00	1	1	2	W29 34	N0057521		
Ø 90	ST H C 8490	I28 W34	127,00	ST H C 8490	E29 W34	127,00	1	1	2	W29 34	N0057521		
Ø 96	ST H C 96102	I30 W34	127,00	ST H C 96102	E31 W34	127,00	1	1	2	W29 34	N0057521		
Ø 102	ST H C 96102	I30 W34	127,00	ST H C 96102	E31 W34	127,00	1	1	2	W29 34	N0057521		
Ø 108	ST H C 108	I81 W24	182,00	ST H C 108	E82 W24	182,00	1	1	3	W29 24	N0057511		
Ø 115	ST H C 115	I83 W34	182,00	ST H C 115	E84 W34	182,00	1	1	3	W29 34	N0057521		
Ø 122	ST H C 122	I85 W34	182,00	ST H C 122	E86 W34	182,00	1	1	3	W29 34	N0057521		
Ø 130	ST H C 130	I79 W34	182,00	ST H C 130	E80 W34	182,00	1	1	3	W29 34	N0057521		
Ø 140	ST H C 140	I87 W34	182,00	ST H C 140	E88 W34	182,00	1	1	3	W29 34	N0057521		
Ø 150	ST H C 150	I77 W42	182,00	ST H C 150	E78 W42	182,00	1	1	3	W29 42	N0057531		
Ø 158	ST H C 158	I75 W42	182,00	ST H C 158	E76 W42	182,00	1	1	3	W29 42	N0057531		
Ø 162	ST H C 162	I73 W42	182,00	ST H C 162	E74 W42	182,00	1	1	3	W29 42	N0057531		
Ø 180	ST H C 96102	I30 W34	127,00	ST H C 96102	E31 W34	127,00	3	1	2	W29 34	N0057521		
Ø 190	ST H C 96102	I30 W34	127,00	ST H C 96102	E31 W34	127,00	3	1	2	W29 34	N0057521		
Ø 200	ST H C 108	I81 W24	182,00	ST H C 108	E82 W24	182,00	3	1	3	W29 24	N0057511		



CARTUCCE PER INSERTI DFT

Cartridges for DFT inserts

Cartucce per punte ST H per inserti KENAMETAL DFT taglia 03-05-06-07
 Cartridges for ST H Drill for KENAMETAL DFT inserts, sizes 03-05-06-07

| gruppo sconto **F040** |

DIAMETRI Max DIAMETRES MAX	CODICE CARTUCCE INTERNE INTERNAL CARTRIDGES CODE			€	CODICE CARTUCCE ESTERNE EXTERNAL CARTRIDGES CODE			€	N° CARTUCCE		N° INSERTI PER CARTUCCIA No. INSERTS FOR CARTRIDGE	TIPO E TAGLIA INSERTI INSERTS TYPE AND SIZE	VITE FISSAGGIO INSERTO DFT... INSERTS FIXING SCREW TYPE DFT
	Int.	Est.	Int.		Est.	Int.	Est.						
Ø 50	ST H C 50	I50 D03	102,00	ST H C 50	E51 D03	102,00	1	1	2	DFT0303	192.432		
Ø 55	ST H C 55	I52 D03	102,00	ST H C 55	E53 D03	102,00	1	1	2	DFT0303	192.432		
Ø 58	ST H C 58	I38 D05	102,00	ST H C 58	E39 D05	102,00	1	1	2	DFT05T3	191.924		
Ø 63	ST H C 63	I23 D05	102,00	ST H C 6368	E24 D05	102,00	1	1	2	DFT05T3	191.924		
Ø 68	ST H C 68	I25 D05	102,00	ST H C 6368	E24 D05	102,00	1	1	2	DFT05T3	191.924		
Ø 73	ST H C 7378	I26 D05	102,00	ST H C 7378	E27 D05	102,00	1	1	2	DFT05T3	191.924		
Ø 78	ST H C 7378	I26 D05	102,00	ST H C 7378	E27 D05	102,00	1	1	2	DFT05T3	191.924		
Ø 84	ST H C 8490	I28 D06	127,00	ST H C 8490	E29 D06	127,00	1	1	2	DFT06T3	191.848		
Ø 90	ST H C 8490	I28 D06	127,00	ST H C 8490	E29 D06	127,00	1	1	2	DFT06T3	191.848		
Ø 96	ST H C 96102	I30 D06	127,00	ST H C 96102	E31 D06	127,00	1	1	2	DFT06T3	191.848		
Ø 102	ST H C 96102	I30 D06	127,00	ST H C 96102	E31 D06	127,00	1	1	2	DFT06T3	191.848		
Ø 108	ST H C 108	I81 D05	182,00	ST H C 108	E82 D05	182,00	1	1	3	DFT05T3	191.924		
Ø 115	ST H C 115	I83 D06	182,00	ST H C 115	E84 D06	182,00	1	1	3	DFT06T3	191.848		
Ø 122	ST H C 122	I85 D06	182,00	ST H C 122	E86 D06	182,00	1	1	3	DFT06T3	191.848		
Ø 130	ST H C 130	I79 D06	182,00	ST H C 130	E80 D06	182,00	1	1	3	DFT06T3	191.848		
Ø 140	ST H C 140	I87 D06	182,00	ST H C 140	E88 D06	182,00	1	1	3	DFT06T3	191.848		
Ø 150	ST H C 150	I77 D07	182,00	ST H C 150	E78 D07	182,00	1	1	3	DFT0704	191.698		
Ø 158	ST H C 158	I75 D07	182,00	ST H C 158	E76 D07	182,00	1	1	3	DFT0704	191.698		
Ø 162	ST H C 162	I73 D07	182,00	ST H C 162	E74 D07	182,00	1	1	3	DFT0704	191.698		
Ø 180	ST H C 96102	I30 D06	127,00	ST H C 96102	E31 D06	127,00	3	1	2	DFT06T3	191.848		
Ø 190	ST H C 96102	I30 D06	127,00	ST H C 96102	E31 D06	127,00	3	1	2	DFT06T3	191.848		
Ø 200	ST H C 108	I81 D05	182,00	ST H C 108	E82 D05	182,00	3	1	3	DFT05T3	191.924		

PUNTE ST HP ST HP DRILL

Ricambi per pattino guida/Spare parts for guide pad

Ø Max	PATTINO GUIDA METALLO DURO	€	VITE REGOLAZIONE PATTINO GUIDA	€	VITE FISSAGGIO PATTINO GUIDA	€
Ø MAX	SOLID CARBIDE GUIDE PAD		GUIDE PAD ADJUSTMENT SCREW		GUIDE PAD FIXING SCREW	
Ø 50	ST H PG 06	40,00	ST H VRG 5X12	3,00	STH VF 5X10	2,60
Ø 55	ST H PG 06	40,00	ST H VRG 5X12	3,00	STH VF 5X10	2,60
Ø 58	ST H PG 06	40,00	ST H VRG 5X12	3,00	STH VF 5X10	2,60
Ø 63	ST H PG 06	40,00	ST H VRG 5X12	3,00	STH VF 5X10	2,60
Ø 68	ST H PG 06	40,00	ST H VRG 5X12	3,00	STH VF 5X10	2,60
Ø 73	ST H PG 08	50,00	ST H VRG 5X12	3,00	STH VF 5X10	2,60
Ø 78	ST H PG 08	50,00	ST H VRG 6X12	3,00	STH VF 6X10	3,00
Ø 84	ST H PG 08	50,00	ST H VRG 6X12	3,00	STH VF 6X10	3,00
Ø 90	ST H PG 08	50,00	ST H VRG 6X12	3,00	STH VF 6X10	3,00
Ø 96	ST H PG 08	50,00	ST H VRG 6X12	3,00	STH VF 6X10	3,00
Ø 102	ST H PG 10	55,00	ST H VRG 6X12	3,00	STH VF 6X10	3,00
Ø 108	ST H PG 10	55,00	ST H VRG 6X12	3,00	STH VF 6X10	3,00
Ø 115	ST H PG 10	55,00	ST H VRG 8X14	3,00	STH VF 8X12	4,00
Ø 122	ST H PG 10	55,00	ST H VRG 8X14	3,00	STH VF 8X12	4,00
Ø 130	ST H PG 10	55,00	ST H VRG 8X14	3,00	STH VF 8X12	4,00
Ø 140	ST H PG 12	65,00	ST H VRG 8X14	3,00	STH VF 8X12	4,00
Ø 150	ST H PG 12	65,00	ST H VRG 8X14	3,00	STH VF 8X12	4,00
Ø 158	ST H PG 12	65,00	ST H VRG 8X14	3,00	STH VF 10X12	5,00
Ø 162	ST H PG 12	65,00	ST H VRG 8X14	3,00	STH VF 10X12	5,00
Ø 180	ST H PG 08	50,00	ST H VRG 6X12	3,00	STH VF 6X10	3,00
Ø 190	ST H PG 08	50,00	ST H VRG 6X12	3,00	STH VF 6X10	3,00
Ø 200	ST H PG 10	55,00	ST H VRG 6X12	3,00	STH VF 6X10	3,00

PUNTE ST HP
ST HP DRILL



Punte pilota/Pilot drills

| gruppo sconto **F040** |

CODICE PUNTE PILOTA PILOT DRILL CODES	DIAMETRI TESTE (max) HEAD DIAMETERS (max)	SPORGENZA PILOTA DA INSERTI PILOT DRILL OVERHANG FROM INSERTS								€
		da/from 2 a 4 x D1		da/from 4 a 6 x D1		> 6 x D1				
		L6	L7	L6	L7	L6	L7	L		
B 510 S 08000 SI35T	Ø50 Ø55 Ø58	3,00	0,80	3,40	1,20	3,80	1,60	27	47,00	
B 510 S 10000 SI35T	Ø63 Ø68 Ø73	4,00	1,30	4,30	1,60	4,60	1,90	36	54,00	
B 510 S 15000 SI35T	Ø78 Ø84 Ø90 Ø96	6,20	2,10	6,50	2,40	6,80	2,70	44	71,00	
B 510 S 20000 SI35T	Ø102 Ø108 Ø115 Ø122	8,10	2,60	8,40	2,90	8,70	3,20	50	93,00	
B 510 S 25000 SI35T	Ø130 Ø140 Ø150 Ø158 Ø162	10,50	3,50	10,90	3,90	11,30	4,30	57	126,00	
B 510 S 30000 SI35T	Ø180 Ø190 Ø200	10,50	3,50	10,90	3,90	11,30	4,30	57	176,00	

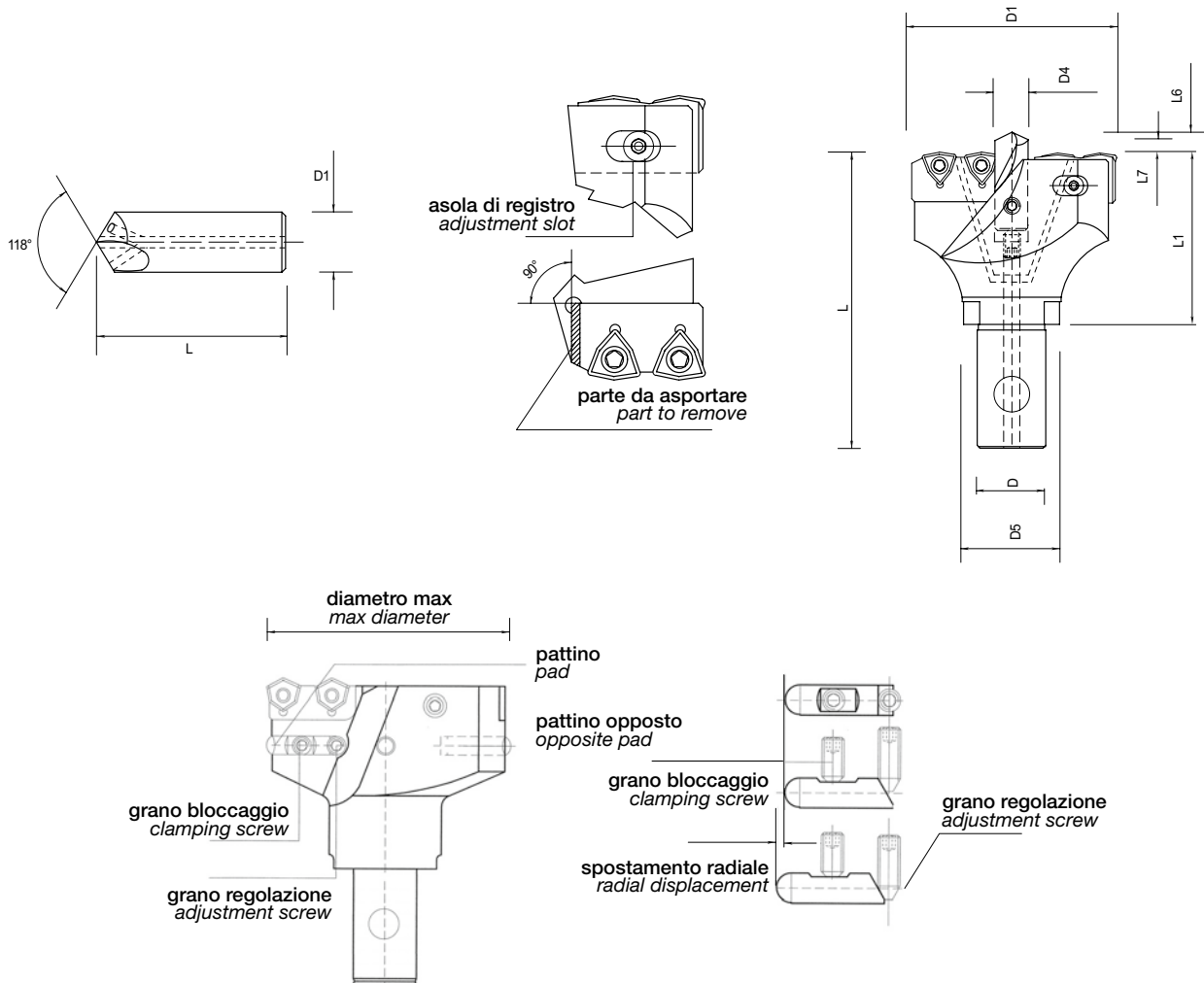

ISTRUZIONI PUNTE ST HP

Per diametri inferiori al diametro nominale:

- modificare il diametro max della punta riducendo la cartuccia esterna.
- l' accorciamento della cartuccia comporta una riduzione del diametro del doppio della misura tolta.
- la misura massima di riduzione diametrale si rileva dal codice punta.

Es. una STHP 50-5 con cartuccia non ridotta fora D. 50 max e D. 45 min.

In base al rapporto tra la lunghezza e il diametro della punta si deve regolare la sporgenza del pilota agendo sulla vite di regolazione pilota (vedi tabella soprariportata).

L'anello di trascinamento viene fornito assieme all'attacco base o prolunga utilizzati.

I pattini di guida riducono lo sbandamento della punta in uscita.

Regolare i pattini ad un diametro leggermente inferiore al quello dell'inserto esterno agendo sulla vite di regolazione e poi su quella di fissaggio.

Non utilizzare i pattini guida con fori corti, in foratura verticale con trucioli non controllati e con lubrificante insufficiente a far uscire i trucioli dal foro.

La centratura non è necessaria su superfici piane. Solo su lunghezze elevate e in modo particolare in applicazioni orizzontali è il caso di eseguire un centrino di diametro minore di quello della punta pilota e con un angolo di testa leggermente maggiore ai 118°.

Non è possibile forare a pacco.

Per quanto riguarda la scelta degli inserti e i parametri di tagli vedere cataloghi Komet e Kennametal.

INSTRUCTIONS ST HP BITS

For diameters that are lower than the nominal diameter:

- *modify the max diameter of the drill by reducing the external cartridge.*
- *the cartridge shortening implies a reduction of the diameter of twice the removed amount..*
- *the maximum size of the diameter reduction can be found in the drill code.*

E.g.: an STHP 50-5 drill with unreduced cartridge drills D 50 max and D 45 min.

It is necessary to adjust the overhang of the pilot drill depending on the ratio between the length and the diameter of the drill by means of the pilot drill adjustment screw (see the table shown above).

The drive ring is supplied along with the base coupling or extension used.

The guide pads limit the careening of the drill as it comes out.

Adjust the pads to a diameter that is slightly minor to that of the external insert using the adjustment screw and then the fixing screw.

Centering is not necessary on flat surfaces. Exclusively in the case of greater lengths and particularly with horizontal applications it is advisable to make a reference mark with a diameter that is smaller than that of the pilot drill and with a head angle that is slightly above 118°.

Drill packing is not possible.

Regarding the choice of inserts and the cutting parameters please see the Komet and Kennametal parameters.



ATTACCHI STKE HP

ATTACCHI STKE HP COUPLINGS STKE HP

Attacchi base e prolunghe per HP Kennametal.

Basic couplings and extensions for Kennametal HP.

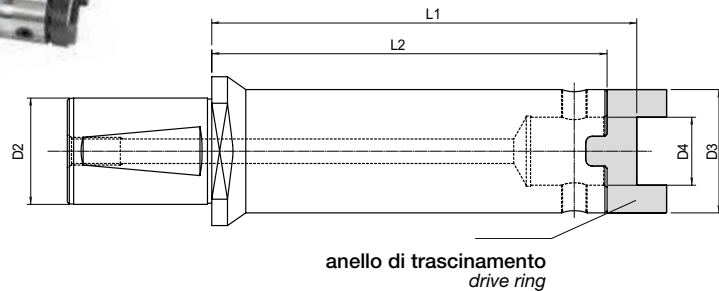

Attacco base per HP/Basic coupling for HP

| gruppo sconto **F045** |

CODICI CODE	Ø ATTACCO D2 Ø COUPLING D2	Ø EST. D3 Ø EXT. D3	Ø FORO D4 Ø HOLE D4	L. UTILE L1 WORKING L1	L. UTILE L2 WORKING L2	Ø MIN-MAX FORO Ø MIN-MAX HOLE	€
STKE AB50 28 13 300	50	28	13	310	300	45/55	475,00
STKE AB50 32 16 200	50	32	16	210	200	55/68	417,00
STKE AB50 32 16 300	50	32	16	310	300	55/68	487,00
STKE AB50 40 22 148	50	40	22	160	148	63/84	380,00
STKE AB50 48 27 168	50	48	27	180	168	78/102	406,00
STKE AB50 58 32 186	50	58	32	200	186	96/115	420,00
STKE AB50 58 32 300	50	58	32	314	300	96/115	512,00
STKE AB50 70 40 150	50	70	40	164	150	115/140	605,00
STKE AB50 70 40 300	50	70	40	314	300	115/140	620,00
STKE AB50 80 50 300	50	80	50	316	300	140/170	720,00

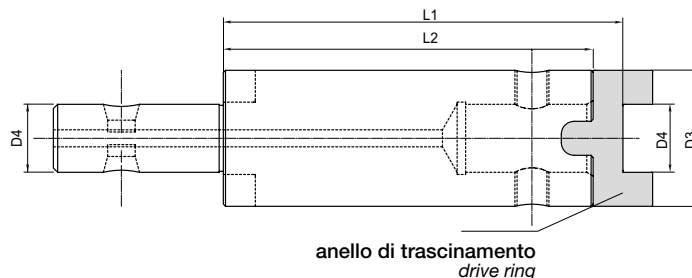

Prolunga per HP/Extension for HP

| gruppo sconto **F045** |

CODICI CODE	Ø EST. D3 Ø EXT. D3	Ø ATTACCO+FORO D4 Ø COUPLING+HOLE D4	L. UTILE L1 WORKING L1	L. UTILE L2 WORKING L2	Ø MIN-MAX FORO Ø MIN-MAX Ø HOLE	€
STKE PR 28 13 150	28	13	160	150	45/55	295,00
STKE PR 32 16 100	32	16	110	100	55/68	299,00
STKE PR 40 22 200	40	22	212	200	63/84	360,00
STKE PR 48 27 200	48	27	212	200	78/102	380,00
STKE PR 58 32 300	58	32	314	300	96/115	511,00
STKE PR 70 40 300	70	40	314	300	115/140	590,00
STKE PR 80 50 150	80	50	166	150	140/170	580,00
STKE PR 80 50 300	80	50	316	300	140/170	620,00

PARTI DI RICAMBIO COMPRESSE NELLA FORNITURA/SPARE PARTS SUPPLIED AS STANDARD

Anello di trascinamento/Drive ring

CODICI CODE	Ø EST. Ø EXT.	Ø FORO Ø HOLE	Ø MIN-MAX FORO Ø MIN-MAX HOLE	VITE SCREW
192.419	28	13	45/55	192.156
192.420	32	16	55/68	192.156
192.421	40	22	63/84	192.157
192.422	48	27	78/102	191.727
192.423	58	32	96/115	191.727
192.424	70	40	115/140	191.728
192.425	80	50	140/170	191.728

