

# MT C ATTACCHI BASE TRILOBATI

## ADATTATORI DI INTERFACCIA MACCHINA ADAPTER FOR MACHINE TOOL EQUIPMENT

Prolunghe e riduzioni.

*Extensions and reduction.*

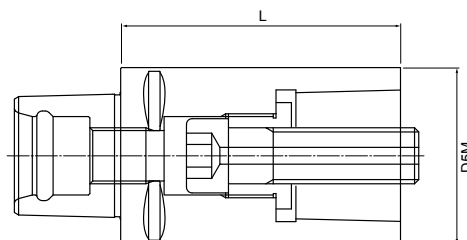

### ADATTATORI DI ESTENSIONE TRILOBATO-TRILOBATO/*Trilobate extension adapter*

| gruppo sconto **MA50** |

CODICE CODE	DIM. CONNESSIONE D5M	L L	€
MT656PV03206000	32	60	<b>192,00</b>
MT656PV03208000	32	80	<b>192,00</b>
MT656PV04006000	40	60	<b>210,00</b>
MT656PV04010000	40	100	<b>216,00</b>
MT656PV05008000	50	80	<b>216,00</b>
MT656PV05010000	50	100	<b>216,00</b>
MT656PV06310000	63	100	<b>240,00</b>
MT656PV06314000	63	140	<b>264,00</b>
MT656PV08010000	80	100	<b>282,00</b>
MT656PV08012500	80	125	<b>300,00</b>

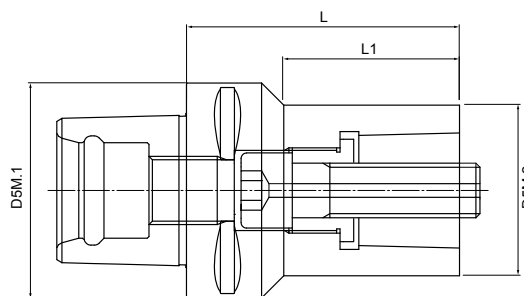

### ADATTATORE DI RIDUZIONE TRILOBATO-TRILOBATO/*trilobate reduction adapter*

| gruppo sconto **MA50** |

CODICE CODE	DIM. ATTACCO D5M.1	DIM. CONNESSIONE D5M.2	L L	L1 L1	€
MT657PV04003200	40	32	70	12	<b>210,00</b>
MT657PV05003200	50	32	60	34,8	<b>216,00</b>
MT657PV05004000	50	40	60	40	<b>216,00</b>
MT657PV05004001	50	40	80	12	<b>216,00</b>
MT657PV06303200	63	32	70	39	<b>240,00</b>
MT657PV06304000	63	40	80	51,4	<b>240,00</b>
MT657PV06305000	63	50	80	51,5	<b>240,00</b>
MT657PV06305001	63	50	120	12	<b>264,00</b>
MT657PV08003200	80	32	60	29,3	<b>282,00</b>
MT657PV08004000	80	40	70	36,5	<b>282,00</b>
MT657PV08005000	80	50	80	49,3	<b>282,00</b>
MT657PV08006300	80	63	80	53,1	<b>282,00</b>
MT657PV08006301	80	63	120	12	<b>300,00</b>
MT657PV10008000	100	80	100	58,2	<b>342,00</b>

## ADATTATORI DI INTERFACCIA MACCHINA

ADAPTER FOR MACHINE TOOL EQUIPMENT

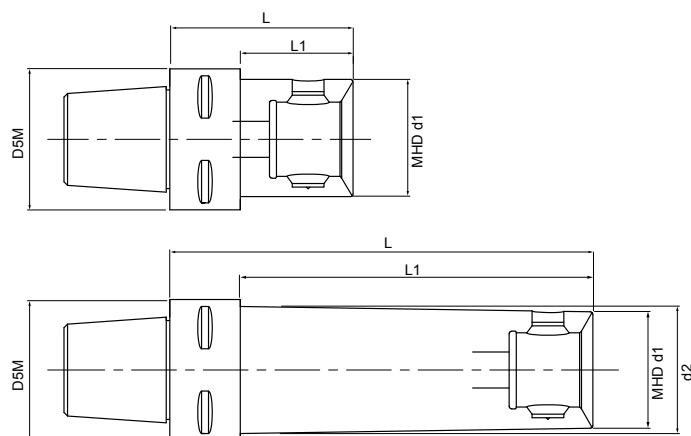

### INGRESSO TRILOBATO CON USCITA MHD / Trilobate adapter for MHD coupling

| gruppo sconto **MA50** |

CODICE CODE	DIM. ATTACCO D5M	DIM. CONNESSIONE MHD d1	D2	L L	L1 L1	€
<b>MT416502606306</b>	63	50	-	67	45	<b>222,00</b>
<b>MT416502606312</b>	63	50	54	120	98	<b>288,00</b>
<b>MT416632606307</b>	63	63	-	77	-	<b>246,00</b>
<b>MT416502608006</b>	80	50	-	60	30	<b>246,00</b>
<b>MT416502608012</b>	80	50	54	120	90	<b>312,00</b>
<b>MT416632608007</b>	80	63	-	70	40	<b>264,00</b>
<b>MT416632608015</b>	80	63	67	150	120	<b>332,40</b>
<b>MT416802608007</b>	80	80	-	75	-	<b>283,20</b>
<b>MT416802608012</b>	80	80	-	120	-	<b>350,40</b>

# MT C ATTACCHI BASE TRILOBATI

## ADATTATORI DI INTERFACCIA MACCHINA

ADAPTER FOR MACHINE TOOL EQUIPMENT

Mandrini base DIN 69871, BT, HSK con connessione trilobata.

Mandrels DIN 69871, BT, HSK with trilobate coupling

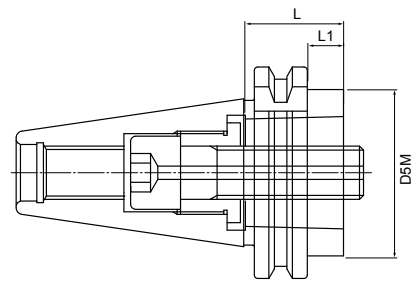
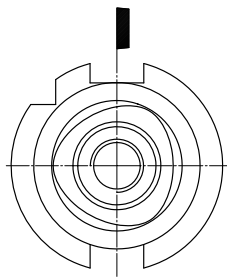

DIN 69871 FORI AD foro centrale/Din 69871 AD central hole

| gruppo sconto MA50 |

CODICE CODE	DIM. ATTACCO DIN	DIM. CONNESSIONE D5M	L L	L1 L1	€
MT41PV05014020	40	50	30	11	210,00
MT41PV06315020	50	63	30	11	264,00

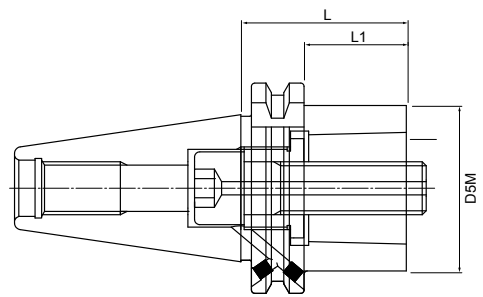
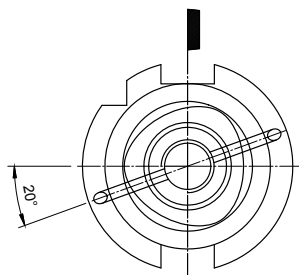

DIN 69871 FORI AD+B foro centrale e su flangia/DIN 69781 AD+B

| gruppo sconto MA50 |

CODICE CODE	DIM. ATTACCO DIN	DIM. CONNESSIONE D5M	L L	L1 L1	€
MT41PV04014021	40	40	30	11	228,00
MT41PV05015021	50	50	30	11	282,00
MT41PV08015021	50	80	70	51	342,00

## ADATTATORI DI INTERFACCIA MACCHINA

ADAPTER FOR MACHINE TOOL EQUIPMENT

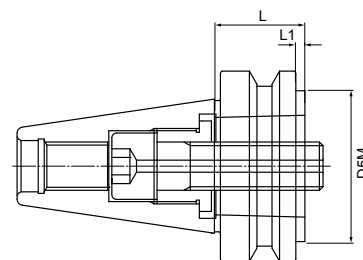
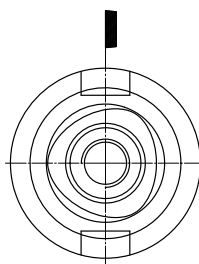

### BT FORI AD foro centrale/BT AD central hole

| gruppo sconto MA50 |

CODICE CODE	DIM. ATTACCO BT	DIM. CONNESSIONE D5M	L L	L1 L1	€
<b>MT41PV05014030</b>	40	50	30	3	<b>210,00</b>
<b>MT41PV06315030</b>	50	63	40	2	<b>264,00</b>

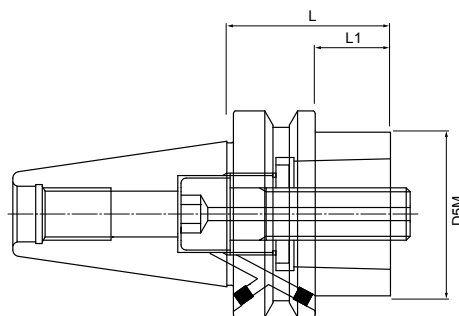
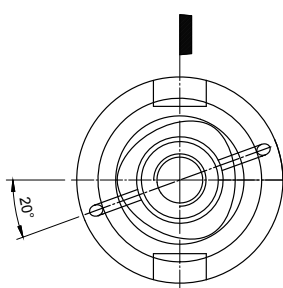

### BT FORI AD+B foro centrale e su flangia/BT AD+B

| gruppo sconto MA50 |

CODICE CODE	DIM. ATTACCO BT	DIM. CONNESSIONE D5M	L L	L1 L1	€
<b>MT41PV04014031</b>	40	40	30	3	<b>228,00</b>
<b>MT41PV05015031</b>	50	50	40	2	<b>282,00</b>
<b>MT41PV08015031</b>	50	80	70	32	<b>342,00</b>

# MT C ATTACCHI BASE TRILOBATI

Portafrese a manicotto, portautensili di precisione a forte serraggio con ingresso trilobato.

Millholder, high precision ultra-tight tollholder with trilobate coupling.

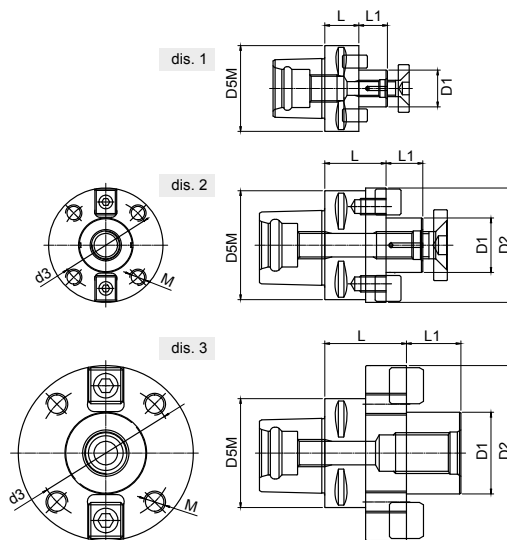

## PORTAFRESE/Millholder

| gruppo sconto MA50 |

CODICE CODE	D5M D5M	D1 D1	D2 D2	D3 D3	M M	L L	L1 L1	dis.	€
<b>MT71TPSC040PF2202</b>	40	22	-	-	-	25	19	1	<b>201,60</b>
<b>MT 71TPSC050PF2202</b>	50	22	-	-	-	25	19	1	<b>213,60</b>
<b>MT 71TPSC050PF2702</b>	50	27	-	-	-	25	21	1	<b>213,60</b>
<b>MT 71TPSC063PF2702</b>	63	27	-	-	-	25	21	1	<b>225,60</b>
<b>MT 71TPSC063PF3202</b>	63	32	-	-	-	25	24	1	<b>240,00</b>
<b>MT 71TPSC080PF3203</b>	80	32	-	-	-	30	24	1	<b>264,00</b>
<b>MT 71TPSC080PF4004</b>	80	40	84	66,7	M12	45	27	2	<b>276,00</b>
<b>MT 71TPSC080PF6006</b>	80	60	128,5	101,6	M16	60	40	3	<b>300,00</b>

Portafrese a manicotto, portautensili di precisione a forte serraggio con ingresso trilobato.

Millholder, high precision ultra-tight tollholder with trilobate coupling.

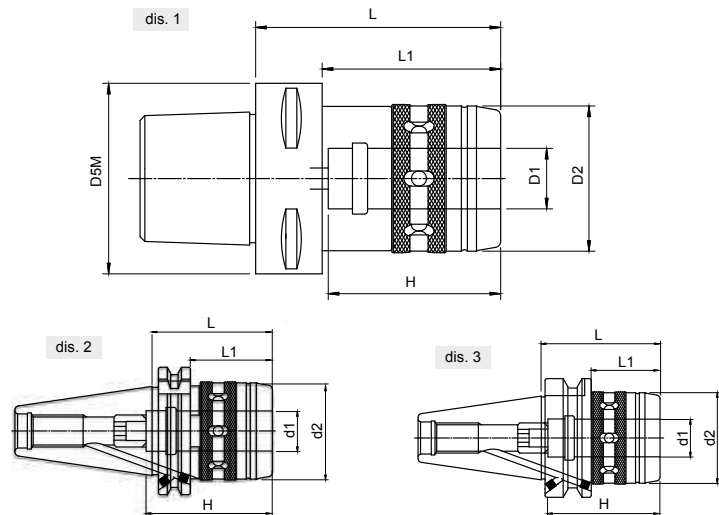

**PORTAUTENSILI FORTE SERRAGGIO/High precision ultra-tight toolholder**

| gruppo sconto **MA50** |

CODICE CODE	D5M D5M	D1 D1	D2 D2	H H	L L	L1 L1	dis.	€
<b>MT 71TPSC063MF2008</b>	63	20	48	60	80	58	1	<b>264,00</b>
<b>MT 71TPSC063MF3210</b>	63	32	66	80	100	-	1	<b>288,00</b>
<b>MT 71TPSC080MF2008</b>	80	20	48	60	80	50	1	<b>390,00</b>
<b>MT 71TPSC080MF3210</b>	80	32	66	80	100	70	1	<b>424,80</b>
<b>MT 71DIN-B40MF2006</b>		20	48	63	60	41	2	<b>228,00</b>
<b>MT 71DIN-B40MF3209</b>		32	66	80	95	-	2	<b>278,00</b>
<b>MT 71DIN-B50MF2008</b>		20	48	63	80	61	2	<b>333,00</b>
<b>MT 71DIN-B50MF3207</b>		32	66	90	75	56	2	<b>376,00</b>
<b>MT 71MBT-B40MF2006</b>		20	20	63	63	36	3	<b>228,00</b>
<b>MT 71MBT-B40MF3209</b>		32	32	80	90	-	3	<b>278,00</b>
<b>MT 71MBT-B50MF2008</b>		20	20	63	85	47	3	<b>333,00</b>
<b>MT 71MBT-B50MF3209</b>		32	32	90	95	57	3	<b>376,00</b>